

Interpenetrative and transverse growth process of self-catalyzed ZnO nanorods

Rusen Yang^a, Zhong Lin Wang^{a,b,*}

^a*School of Materials Science and Engineering, Georgia Institute of Technology, 771 Ferst Dr, Atlanta, GA 30332-0245, USA*

^b*National Center for Nanoscience and Technology, Beijing 100080, China*

Received 23 February 2005; accepted 14 March 2005 by C.N.R. Rao

Available online 29 March 2005

Abstract

Beside longitudinal growth along the length, we show that ZnO nanorods also exhibit transverse growth, which is responsible for the formation of interpenetrative nanorods. The longitudinal growth is lead by the catalytically active Zn-terminated (0001) surface, while the oxygen-terminated (000 $\bar{1}$) surface is catalytically inactive, resulting in the formation of ‘pencil’ or ‘bullet’ shaped nanostructures.

© 2005 Elsevier Ltd. All rights reserved.

PACS: 61.46

Keywords: A. Nanorods; A. Nanowires

Being a wide band-gap (3.37 eV) semiconductor with a high exciton binding energy (60 meV), ZnO is suitable for short-wavelength optoelectronics [1] and transparent conducting windows for solar cells [2]. The piezoelectricity due to its non-centrosymmetric structure enables ZnO being an important material for electro-mechanical coupled sensors [3] and actuators [4]. Since the discovery of ZnO nanobelt [5], a variety of ZnO nanostructures have been synthesized [6–9] and research in one-dimensional (1D) oxide nanostructures (nanowires, nanorods and nanobelts) is being greatly accelerated.

Growth of 1D nanostructures is mainly attributed to a vertical growth model, in which the nanostructure is believed to grow along its length direction (the longitudinal growth) and there is little growth across its diameter/width

(the transverse growth), because most of the 1D nanostructures have uniform structures along their lengths. The size of the nanostructure is believed to be defined at the very beginning of the growth. In this paper, we report a case that demonstrates the transverse growth of the nanorods across their width, which is distinct from the traditional model. Using the growth of ZnO nanorods without catalyst as an example, we first illustrate the interpenetrative structures of nanorods at an arbitrary angle. Then, the self-catalyst growth at the Zn-terminated (0001) surface is presented, which is responsible for the formation of ‘pencil’ or ‘bullet’ shaped structure. The formation of interpenetrative tapering nanorods is due to self-catalyzed asymmetrical growth together with the transverse growth. The understanding of this growth mechanism gives some insight about the formation of complex oxide nanostructures.

The interpenetrative nanorods were synthesized through a thermal evaporation process in a horizontal tube furnace. Commercial grade ZnO powder was placed in the center of a single zone tube furnace and evacuated for several hours to purge oxygen in the chamber. Polycrystalline alumina

* Corresponding author. Address: School of Materials Science and Engineering, Georgia Institute of Technology, 771 Ferst Dr, Atlanta, GA 30332-0245, USA. Tel.: +1 404 894 8008; fax: +1 404 894 9140.

E-mail address: zhong.wang@mse.gatech.edu (Z.L. Wang).

substrate was used for growing the nanostructures. After the evacuation the temperature of the system was elevated to the synthesis temperature of 1370 °C with Ar running through at the rate of 50 sccm. The pressure was kept at 500 mbar before the temperature reached 800 °C and 200 mbar afterward. The as-synthesized products were analyzed by scanning electron microscope (SEM) and transmission electron microscope (TEM)

ZnO nanorods of uniform size have been synthesized by a solid-vapor phase process directly by vaporizing ZnO powder without using catalyst (Fig. 1(a)). Most of the nanorods grow vertically upwards and they are separated from each other. The nanorods with uniform diameter around 800 nm were collected at a temperature region of about 500 °C. But a close examination has found that some of the nanorods are interpenetrative (Fig. 1(b)). This is a rather unique feature. The facets at the side and at the front of the nanorods are well defined and flat. The ‘pencil’ or ‘bullet’ shape of the nanorods can be seen through the SEM image displayed in Fig. 1(c), where one end of the nanorod is flat and the other end is a sharp tip.

The nanorods collected in a temperature region of 450 °C are less dense (Fig. 2(a)). The diameter of the nanorods is about 600 nm. Compared to the nanorods in Fig. 1(b), the nanorods in Fig. 2 have small pyramids at the growth fronts. The diamond-shaped facets at the growth front are larger and the trapezoidal shape facets become triangular shape (Fig. 2(b)). In spite of the appearance of pyramids, the nanorods still penetrate each other freely as shown in Fig. 2(c) and there is no specific angle at which the two intercept.

With a further decrease in local growth temperature to 400 °C, the hexagonal pyramid at the center of the tip is

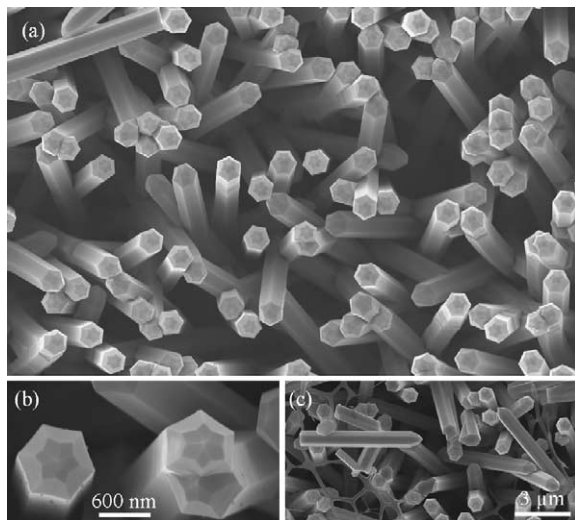

Fig. 1. (a) SEM image showing a high percentage of interpenetrative nanorods in the sample collected at a local temperature of 500 °C. (b) SEM image showing the well-defined facets on the tip. (c) The ‘pencil’ or ‘bullet’ shaped morphology of the nanorod.

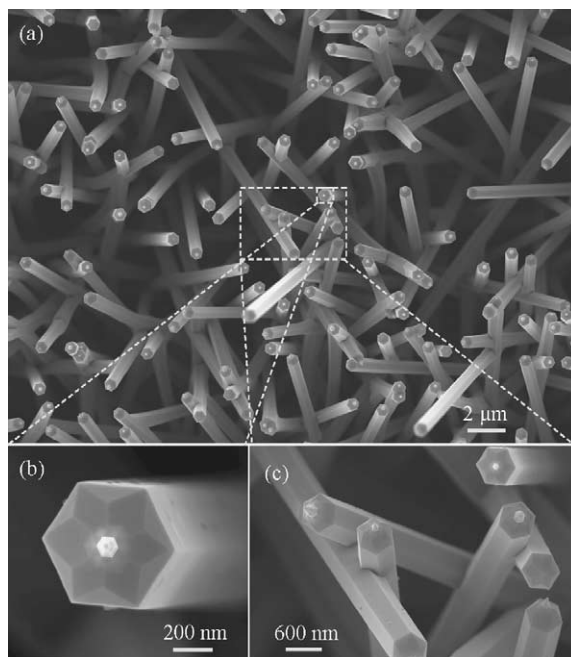

Fig. 2. (a) SEM image showing interpenetrative nanorods in the sample collected at a local temperature of 450 °C. (b) SEM image showing the well-defined facets and a small pyramid at the tip. (c) The interpenetrative structure with small pyramids on the tips.

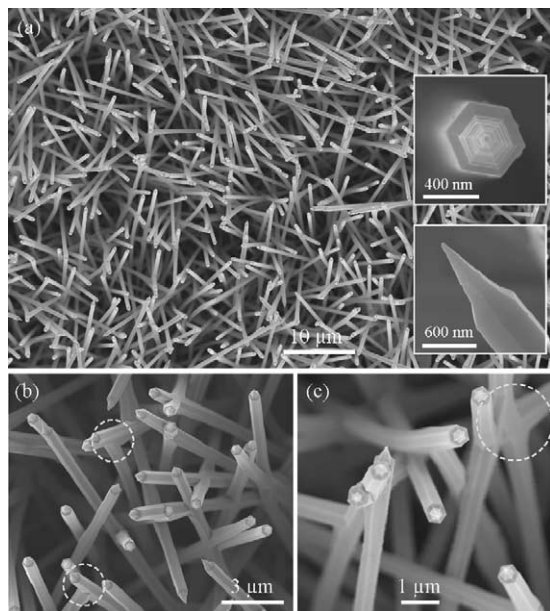

Fig. 3. (a) SEM image showing interpenetrative nanorods in the sample collected at a local temperature of 400 °C. The insets show clearly the evenly spaced stairs on the sharp cone-shaped tip. (b) SEM image showing nanorods that are either interpenetrative or terminated at other nanorods. (c) Swelling and bent at the nanorod intersection.

getting larger, while the diameter of the nanorods becomes smaller (Fig. 3). From the inserts in Fig. 3(a), the side surface of the pyramid is not a flat facet but evenly spaced stairs. Besides a significant percentage of interpenetrative nanorods, the nanorods terminated at other nanorods are also found, as shown in the circled regions in Fig. 3(b). The interpenetrative nanorods still preserve the hexagonal shape and growth direction after crossing. But the nanorods are slightly swelled at the intersection, as seen inside the circle in Fig. 3(c), which implies that the nanorods can have a transversal growth besides the fast longitudinal growth. These are important features of the interpenetrating nanorods.

The nanorods at the interpenetration site often inflate due to transverse growth, as seen inside the circle in Fig. 4(a), which is a clear indication of joining of one nanorod over the other one after crossing. The nanorods grew longitudinally first, the physical contact and a subsequent transverse growth result in joining. Fig. 4(a) also shows another configuration of two nanorods that joint together at the end when the growth fronts meet (as indicated by an arrowhead). The bending of the nanorods is apparent. In the case that a

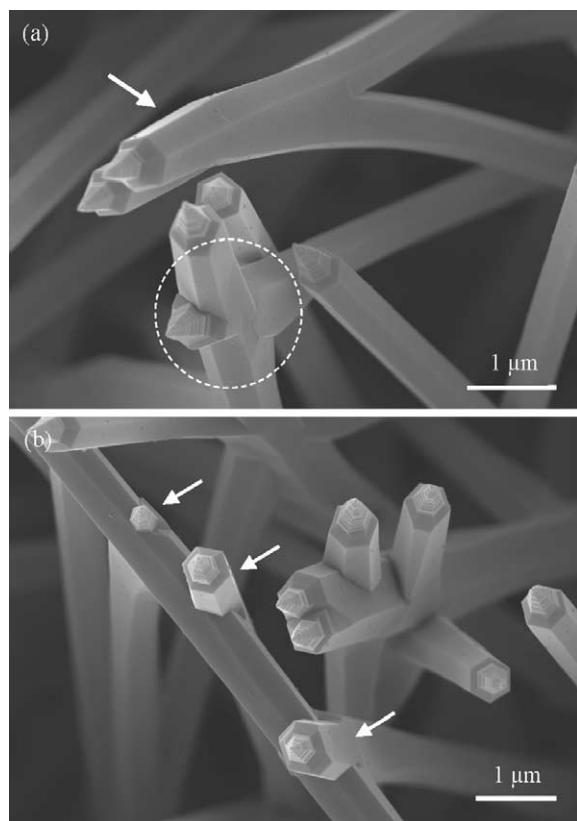

Fig. 4. (a) SEM image showing the swelled intersection and a tortuous configuration due to the competition growth between the nanorods. (b) A nanorod that was intersected by three nanorods. The right-hand is a complex interpenetrative structure.

nanorod meets a pre-existing nanorod, the nanorod tends to pass the existing one by taking a by-pass approach but with joint volume, as indicated by arrowheads in Fig. 4(b). The existing nanorod does not change much, while the newly grown nanorod inflates due to the transversal growth, as suggested by the structure displayed in Fig. 4(b). The nanorod still preserves the hexagonal shape after passing the existing nanorod due to the lower energy of the $\{2\bar{1}\bar{1}0\}$ or

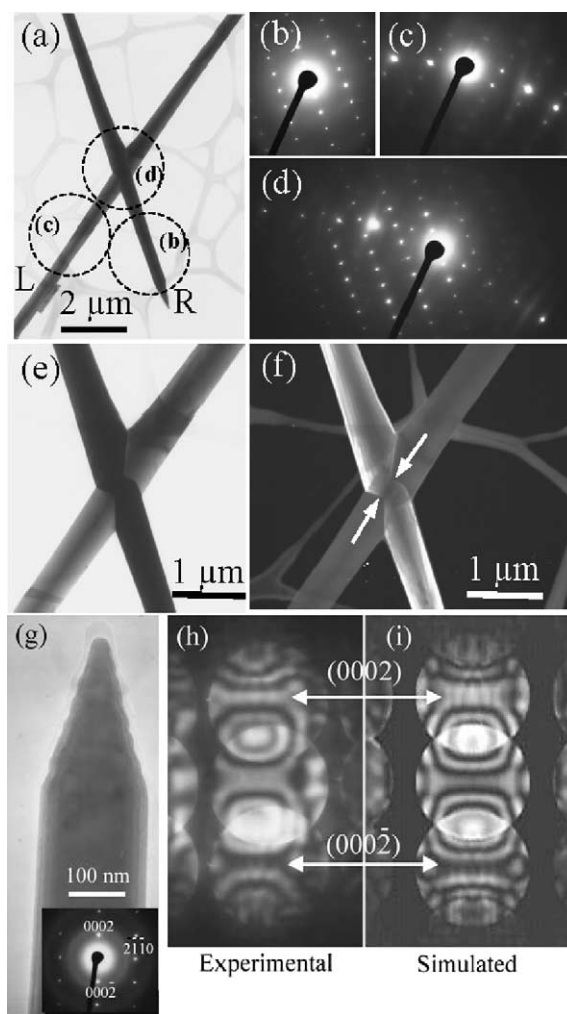

Fig. 5. (a) TEM image of two interpenetrative nanorods, labeled L and R. (b)–(d) are selected area electron diffraction patterns from R, L and their intersection region, respectively. (e) and (f) Bright-field and dark-field TEM images of the intersection. (g) TEM image of a nanorod and its corresponding selected area electron diffraction pattern. (h) An experimental CBED pattern recorded from the nanorod using an electron beam of 3 nm in diameter. (i) A simulated CBED pattern using dynamic electron diffraction theory. The simulation includes 127 beams in both zero order and high order Laue zones and Debye–Waller factor at room temperature. The best match was found at thickness of 165 nm. $V=200$ kV and beam direction $[01\bar{1}0]$.

$\{01\bar{1}0\}$ facets. In addition, one nanorod at the upper right-hand side in Fig. 4(b) splits into two nanorods due to the transversal growth after the penetration.

The joining point of two nanorods has been imaged by TEM. Fig. 5(a) is a bright-field TEM image of two interpenetrating nanorods, labeled L and R. Selected area electron diffraction (SAED) patterns were recorded from the areas indicated to be b, c and d without tilting the sample and the results are shown in Fig. 5(b)–(d), respectively. The SAED pattern in Fig. 5(b) shows that the nanorod R grows along $[0001]$ and the electron beam is $[2\bar{1}\bar{1}0]$. The SAED pattern recorded from the nanorod L (Fig. 5(c)) shows the Laue circle, indicating that the nanorod orientation is far from a zone axis. The SAED pattern from the crossing region is an overlap of two patterns (Fig. 5(d)), clearly indicating that the two nanorods have no orientation relationship and the nanorods preserve their own orientation before and after interpenetrating with each other. This is very different from the twin, tetraleg [10] or nanopropeller [11] structures for ZnO, which have specific angles defined by crystallography. To confirm this observation, bright-field and dark field TEM images were recorded from the crossing area, as shown in Fig. 5(e) and (f), respectively. The images suggest that the L nanorod was formed first, then the R nanorod contacted the L nanorod at a width indicated by two arrowheads in Fig. 5(f). The subsequent transverse growth forms the joining of the two nanorods and their observed widths.

To understand the formation of the pencil or bullet structure of the $[0001]$ nanorods, we first examine the structure of ZnO. Wurtzite ZnO crystal can be viewed as a number of alternating layers of tetrahedrally co-ordinated O^{2-} and Zn^{2+} ions, stacked alternatively along the c -axis. The negative charged $(000\bar{1})-O^{2-}$ layers and the positively charged $(0001)-Zn^{2+}$ layers result in the spontaneous polarization along positive c -axis. To identify the polarity of the nanorod, we have applied the convergent beam electron diffraction (CBED). Due to the strong dynamic diffraction effect of electrons in a crystal, the polarity of

ZnO can be determined using CBED by quantifying the electron diffraction intensity as a function of the incident angle of the electron beam. Fig. 5(g) shows a TEM image of a nanorod and its corresponding SAED pattern, which indicates that the nanorod grows along $[0001]$. Fig. 5(h) is a CBED pattern recorded from the nanorod by using a convergent electron beam. Thus, the diffraction spot becomes a disk. The detailed intensity distribution within the disk is related to the crystal structure and sample thickness. The intensity distributions in the (0002) and $(000\bar{2})$ disks are non-symmetric due to the polarity of the ZnO structure [12]. Quantitative interpretation of the CBED relies on dynamic electron diffraction simulations, which were performed using an improved version of the Bloch wave program [13] and the structure data from single crystal neutron diffraction [14]. A comparison of the experimental pattern with a theoretically calculated pattern is given in Fig. 5(h) and (i) and the excellent agreement between the two indicates that the nanorod grows out of the positively charged (0001) -Zn surface. Therefore, the sharp tip is due to the catalytically active (0001) -Zn surface, while the flat surface at the bottom is the chemically inactive $(000\bar{1})$ -O surface, forming the pencil or bullet shape structure (Fig. 1(c)). The growth is thus due to self-catalysis of Zn-terminated (0001) surface [15].

The information provided by SEM and TEM enables us to propose a growth model, in which both longitudinal growth and transverse growth co-exist, but the former is a lot faster than the latter. Due to the distinct catalytic activities of the Zn- and O-terminated surfaces, the nanorod grow along $[0001]$, possibly forming a growth tip at the front that is terminated with Zn. The transversal growth along either $(2\bar{1}\bar{1}0)$ or $(01\bar{1}0)$ is negligible in comparison to the longitudinal growth. When the growth front of a nanorod meets a grown nanorod, the grown nanorod behaves like a pre-existing nanorod (Fig. 6(a)). If the two nanorods cross at a larger angle, the latter coming one may be partially terminated by the grown nanorod and partially by-pass the nanorod (Fig. 6(b)) (see the nanorods indicated by

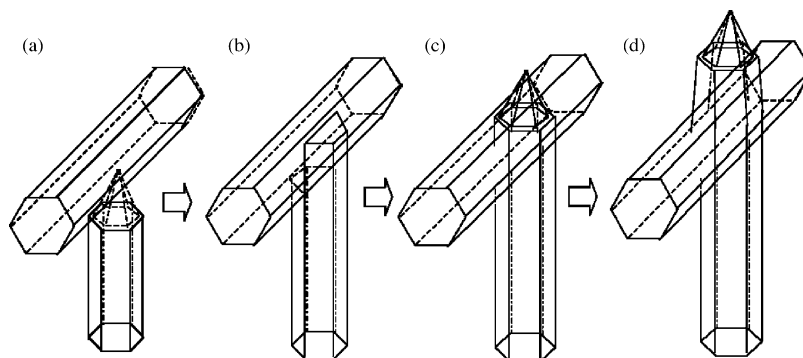

Fig. 6. Interpenetrative and transversal growth model for the formation of crossed nanorods. (a) The growth forefront of bottom nanorod encounters the top nanorod. (b) Only the unblocked part can still continue with longitudinal growth. (c) The bottom nanorod regains its hexagonal shape through transversal growth. (d) The bottom rod continues with longitudinal growth after the penetration.

arrowheads in Fig. 4(b)) and its continuous growth leads to the formation of the front tip on the body of the grown nanorod (Fig. 6(c)). A continuous growth both longitudinally and transversely leads to the joining of the two nanorods (Fig. 6(d)) (Figs. 2(c), 3(c) and 4). Facets are preserved due to the symmetry and lower energy surfaces of the crystal structure. Transversal growth continues when source material is continuously supplied, resulting in the tortuous or bent shape at the intersection. If two crossing nanorods happen to have twin orientation relationship, accomplishment of the penetration can also result in a twin boundary, which has also been observed in our sample.

In summary, we have presented evidence showing the transverse growth of nanorods. This is a significant progress in understanding the formation of 1D nanostructures, because the transverse growth has been ignored in many cases. The interpenetrative growth of two nanorods at a random angle has been illustrated for ZnO. The Zn-terminated (0001) surface has been shown to be catalytically active, while the oxygen-terminated (000 $\bar{1}$) is catalytically inert; the former is responsible for forming the sharp tip at the growth front. A model is proposed for understanding the formation of the interpenetrative nanorods.

Acknowledgements

Thanks to the financial support from the US NSF NIRT ECS-0210332. Thanks to Daniel Moore for calibrating the furnace and Prof J. M. Zuo for providing the simulation program for CBED.

References

- [1] X.D. Wang, C.J. Summers, Z.L. Wang, *Nano Lett.* 4 (2004) 423.
- [2] S.B. Qadri, H. Kim, J.S. Horwitz, D.B. Chrisey, *J. Appl. Phys.* 88 (2000) 6564.
- [3] A. Kuoni, R. Holzherr, M. Boillat, N.F. de Rooij, *J. Micromech. Microeng.* 13 (2003) S103.
- [4] F.R. Blom, D.J. Yntema, F.C.M. Van de Pol, M. Elwenspoek, J.H.J. Fluitman, Th.J.A. Popma, *Sens. Actuators A-Phys.* A21 (1990) 226.
- [5] Z.W. Pan, Z.R. Dai, Z.L. Wang, *Science* 291 (2001) 1947.
- [6] Z.L. Wang, *J. Phys.: Condens. Matter* 16 (2004) R829.
- [7] X.Y. Kong, Y. Ding, R.S. Yang, Z.L. Wang, *Science* 303 (2004) 1348.
- [8] X.Y. Kong, Z.L. Wang, *Nano Lett.* 3 (2003) 1625.
- [9] Z.L. Wang, X.Y. Kong, Y. Ding, P.X. Gao, W.L. Hughes, R.S. Yang, Y. Zhang, *Adv. Funct. Mater.* 14 (2004) 944.
- [10] Y. Dai, Y. Zhang, Q.K. Li, C.W. Nan, *Chem. Phys. Lett.* 358 (2002) 83.
- [11] P.X. Gao, Z.L. Wang, *Appl. Phys. Lett.* 84 (2004) 2883.
- [12] F. Vigue, P. Vennegues, S. Veizian, M. Laugt, J.-P. Faurie, *Appl. Phys. Lett.* 79 (2001) 194.
- [13] J.C.H. Spence, J.M. Zuo, *Electron Microdiffraction*, Plenum, New York, 1992.
- [14] T.M. Sabine, S. Hogg, *Acta Cryst.* 25 (1969) 2254.
- [15] Z.L. Wang, X.Y. Kong, J.M. Zuo, *Phys. Rev. Lett.* 91 (2003) 185502.